

## General Description

The Sanrise SRC60R140B is a high voltage power MOSFET, fabricated using advanced super junction technology. The resulting device has extremely low on resistance, low gate charge and fast switching time, making it especially suitable for applications which require superior power density and outstanding efficiency.

The SRC60R140B break down voltage is 600V and it has a high rugged avalanche characteristics. The SRC60R140B is available in TO-220F and TO-220C packages.

## Features

- Ultra Low  $R_{DS(ON)} = 140m\Omega @ V_{GS} = 10V$ .
- Ultra Low Gate Charge,  $Q_g=40.4nC$  typ.
- Intrinsic Fast-Recovery Body Diode
- Fast switching capability
- Robust design with better EAS performance

## Application

- AC/DC Power Supply
- PC Power
- Sever / Telecom
- Solar Inverter

## Symbol

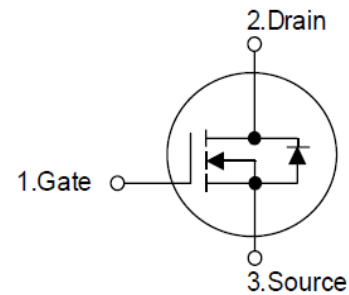

Figure 1 Symbol of SRC60R140B

## Package Type

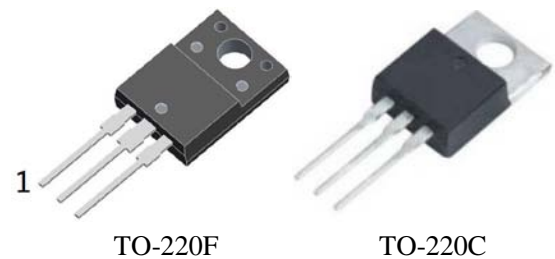
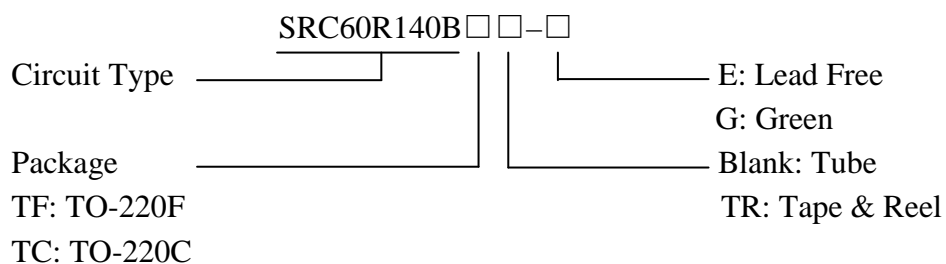

Figure 2 Package Types of SRC60R140B

## Ordering Information



Package	Part Number		Marking ID		Packing Type
	Lead Free	Green	Lead Free	Green	
TO-220F	SRC60R140BTF-E	SRC60R140BTF-G	SRC60R140BTFE	SRC60R140BTFG	Tube
TO-220C	SRC60R140BTC-E	SRC60R140BTC-G	SRC60R140BTCE	SRC60R140BTCG	Tube

**Absolute Maximum Ratings**

Parameter		Symbol	Rating	Unit
Drain-Source Voltage		$V_{DSS}$	630	V
Gate-Source Voltage		$V_{GSS}$	±30	V
Continuous Drain Current	$T_C=25^{\circ}C$	$I_D$	25.0	A
	$T_C=125^{\circ}C$		11.2	
Pulsed Drain Current (Note 2)		$I_{DM}$	76	A
Avalanche Energy, Single Pulse (Note 3)		$E_{AS}$	510	mJ
Avalanche Energy, Repetitive (Note 2)		$E_{AR}$	0.7	mJ
Avalanche Current, Repetitive (Note 2)		$I_{AR}$	3.6	A
Continuous Diode Forward Current		$I_S$	25.0	A
Diode Pulse Current		$I_{S,PULSE}$	76	A
Operating Junction Temperature		$T_J$	150	°C
Storage Temperature		$T_{STG}$	-55 to 150	°C
Lead Temperature (Soldering, 10 sec)		$T_{LEAD}$	260	°C

Note:

1. Absolute maximum ratings are those values beyond which the device could be permanently damaged. Absolute maximum ratings are stress ratings only and functional device operation is not implied.
2. Repetitive Rating: Pulse width limited by maximum junction temperature
3.  $I_{AS} = 3.6A$ ,  $V_{DD} = 60V$ ,  $R_G = 25\Omega$ , Starting  $T_J = 25^{\circ}C$

**Electrical Characteristics**

$T_J = 25\text{ }^\circ\text{C}$ , unless otherwise specified.

Parameter	Symbol	Test Conditions	Min	Typ	Max	Unit
Drain-Source Breakdown Voltage	$BV_{DSS}$	$V_{GS}=0V, I_D=250\mu A$	600			V
Zero Gate Voltage Drain Current	$I_{DSS}$	$V_{DS}=600V, V_{GS}=0V$			10	$\mu A$
Gate-Body Leakage Current	Forward	$I_{GSSF}, V_{GS}=30V, V_{DS}=0V$			100	nA
	Reverse	$I_{GSSR}, V_{GS}=-30V, V_{DS}=0V$			-1.0	$\mu A$
Gate Threshold Voltage	$V_{GS(TH)}$	$V_{DS}=V_{GS}, I_D=250\mu A$	2.3	3.3	4.3	V
Static Drain-Source On-Resistance	$R_{DS(ON)}$	$V_{GS}=10V, I_D=13.0A$		126	140	mΩ
Gate Resistance	$R_G$	f=1MHz, Open Drain		1.7		Ω
<b>Dynamic Characteristics</b>						
Input Capacitance	$C_{ISS}$	$V_{DS}=50V, V_{GS}=0V, f=1MHz$		1650		pF
Output Capacitance	$C_{OSS}$			129.6		
Reverse Transfer Capacitance	$C_{RSS}$			10.1		
Effective output capacitance, energy related <sup>NOTE4</sup>	$C_{O(er)}$	$V_{GS}=0V, V_{DS}=0\dots 480V$		76.8		pF
Effective output capacitance, time related <sup>NOTE5</sup>	$C_{O(tr)}$			281		
Turn-on Delay Time	$t_{d(on)}$	$V_{DD}=400V, I_D=13.0A, R_G=3.4\Omega, V_{GS}=10V$		11		ns
Rise Time	$t_r$			10		
Turn-off Delay Time	$t_{d(off)}$			76		
Fall Time	$t_f$			8		
<b>Gate Charge Characteristics</b>						
Gate to Source Charge	$Q_{gs}$	$V_{DD}=480V, I_D=13.0A, V_{GS}=0\text{ to }10V$		10.8		nC
Gate to Drain Charge	$Q_{gd}$			13.9		
Gate Charge Total	$Q_g$			40.4		
Gate Plateau Voltage	$V_{plateau}$			5.4		V
<b>Reverse Diode Characteristics</b>						
Drain-Source Diode Forward Voltage	$V_{SD}$	$V_{GS}=0V, I_{SD}=13.0A$		0.90	1.1	V
Reverse Recovery Time	$t_{rr}$	$V_R=400V, I_F=13.0A, dI_F/dt=100.0A/\mu s$		124		ns
Reverse Recovery Charge	$Q_{rr}$			0.59		$\mu C$
Peak Reverse Recovery Current	$I_{rrm}$			9.5		A

Note:

4.  $C_{O(er)}$  is a fixed capacitance that gives the same stored energy as  $C_{OSS}$  while  $V_{DS}$  is rising from 0 to 480V

5.  $C_{O(tr)}$  is a fixed capacitance that gives the same charging time as  $C_{OSS}$  while  $V_{DS}$  is rising from 0 to 480 V

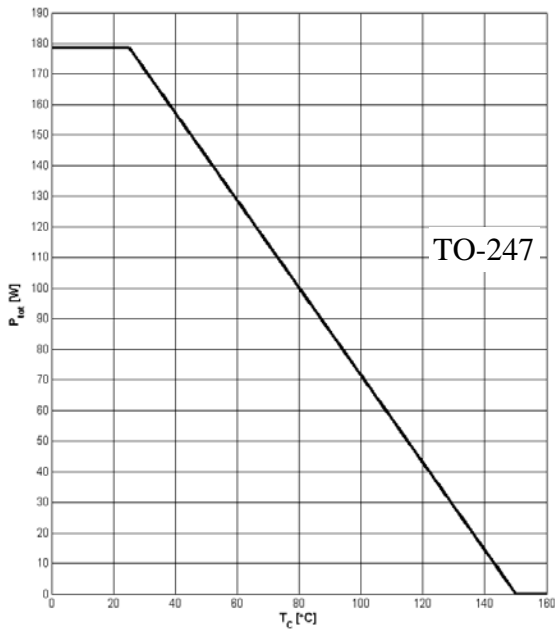
**Typical Performance Characteristics**
**Figure 3: Power Dissipation**

$$P_{tot} = f(T_c)$$

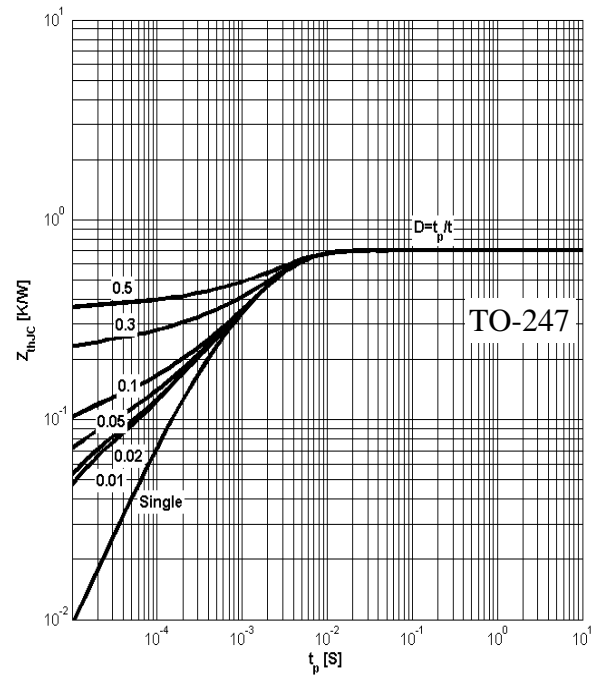
**Figure 4: Max. Transient Thermal Impedance**

$$Z_{(th)JC} = f(t_p); \text{ parameter: } D = t_p/T$$

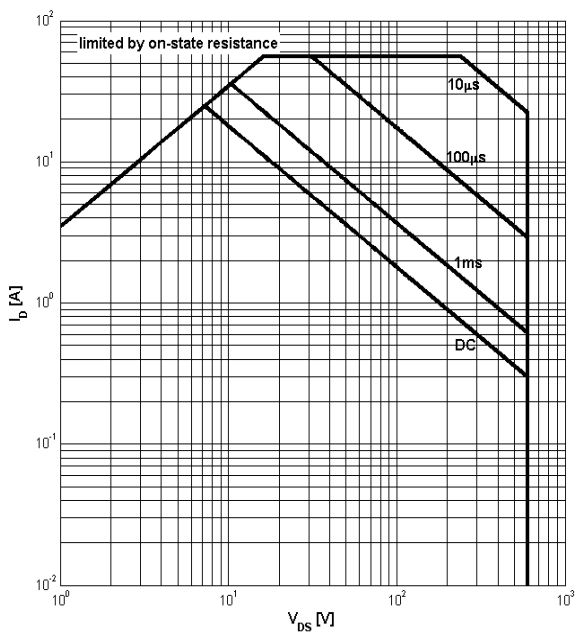
**Figure 5: Safe Operating Area**

$$I_D = f(V_{DS}); T_c = 25^\circ\text{C}; V_{GS} > 7\text{V}; \text{ parameter } t_p$$

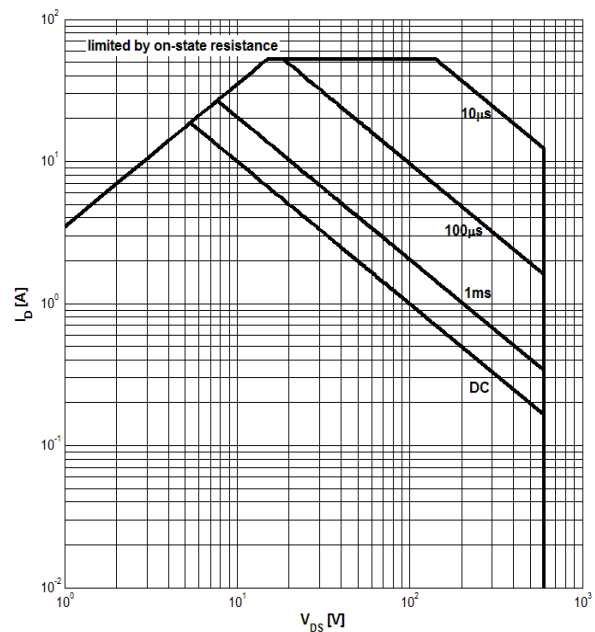
**Figure 6: Safe Operating Area**

$$I_D = f(V_{DS}); T_c = 80^\circ\text{C}; V_{GS} > 7\text{V}; \text{ parameter } t_p$$

**Figure 7: Typ. Output Characteristics**

 $I_D = f(V_{DS}); T_j = 25^\circ\text{C}; \text{parameter: } V_{GS}$ 
**Figure 8: Typ. Output Characteristics**

 $I_D = f(V_{DS}); T_j = 125^\circ\text{C}; \text{parameter: } V_{GS}$ 
**Figure 9: Typ. Drain-Source On-State Resistance**

 $R_{DS(ON)} = f(I_D); T_j = 125^\circ\text{C}; \text{parameter: } V_{GS}$ 
**Figure 10: Typ. Drain-Source On-State Resistance**

 $R_{DS(ON)} = f(T_j); I_D = 13\text{A}; V_{GS} = 10\text{V}$

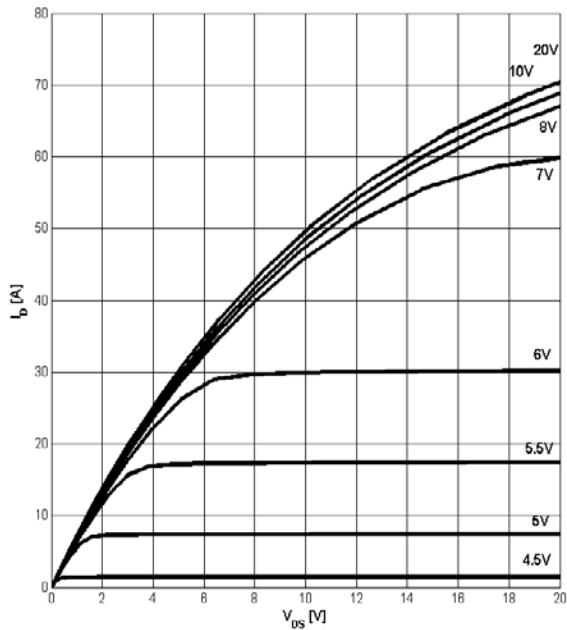
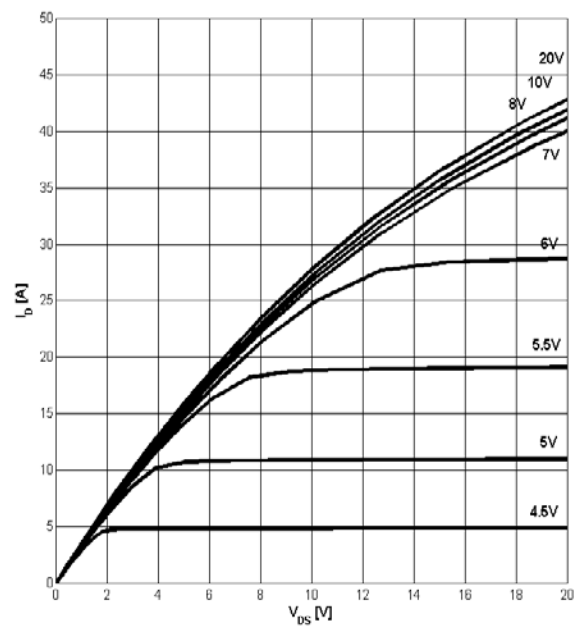
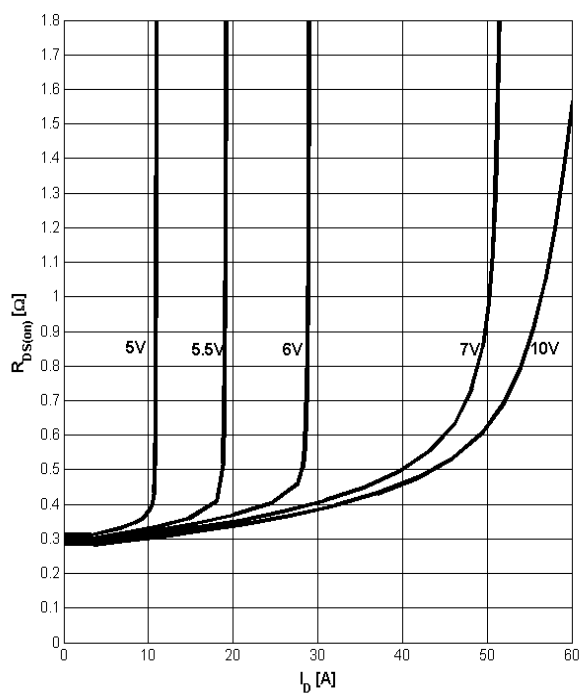
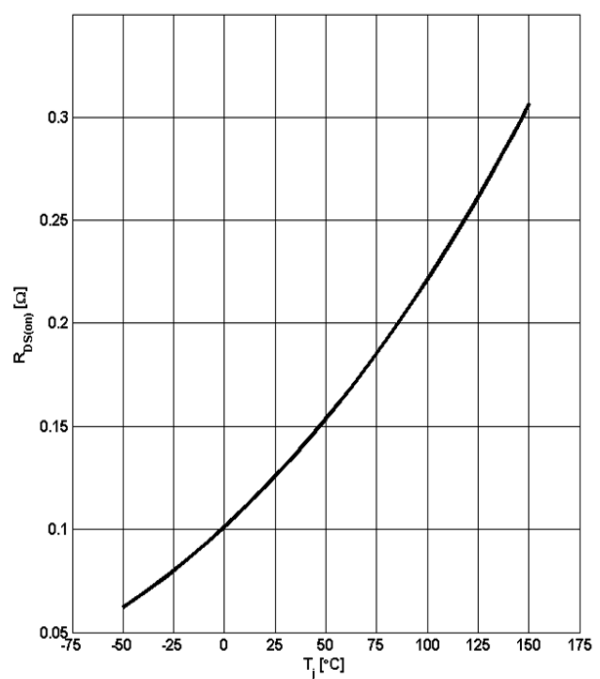
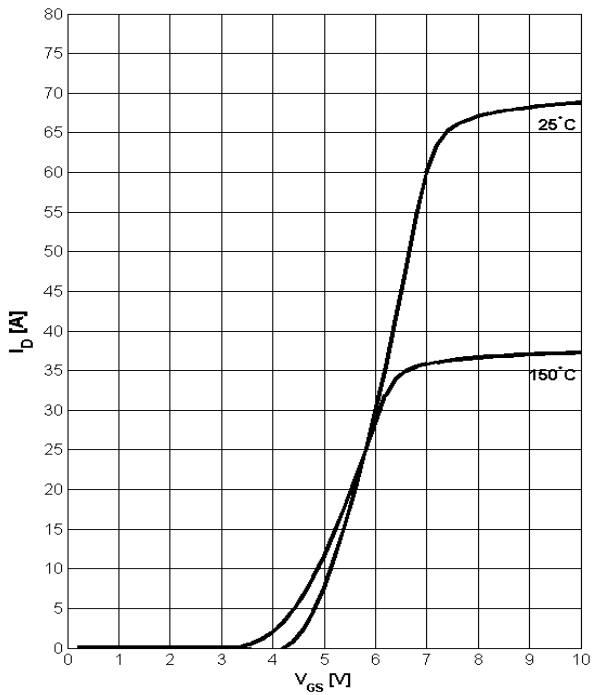
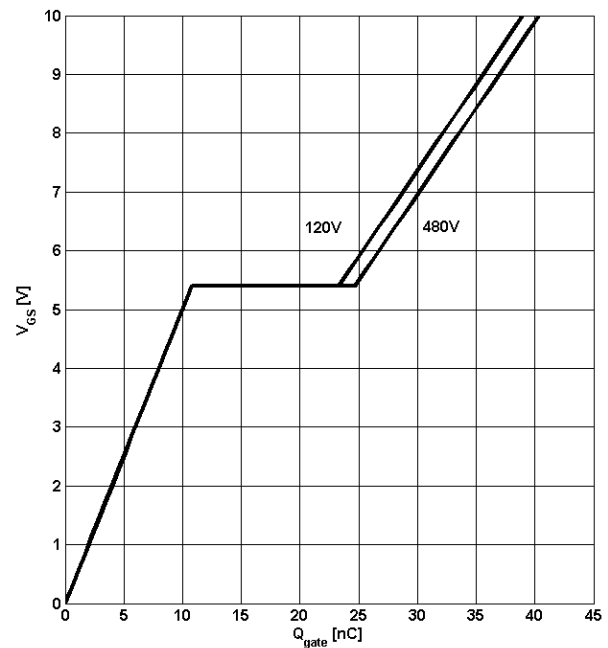
Figure 11: Typ. Transfer Characteristics



$I_D = f(V_{GS}); V_{DS} = 20V$

Figure 12: Typ. Gate Charge



$V_{GS} = f(Q_{gate}), I_D = 13A \text{ pulsed}$

Figure 13: Drain-Source Breakdown Voltage

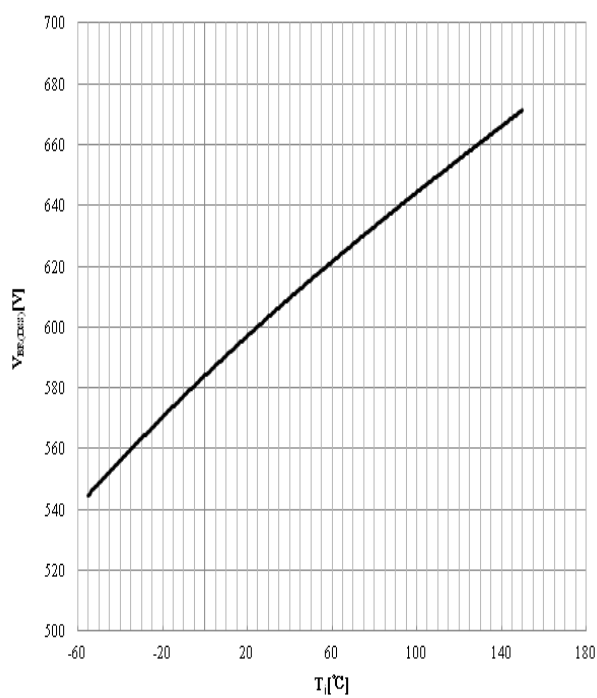

$V_{BR(DSS)} = f(T_j); I_D = 1mA$

Figure 14: Forward Characteristics of Reverse Diode

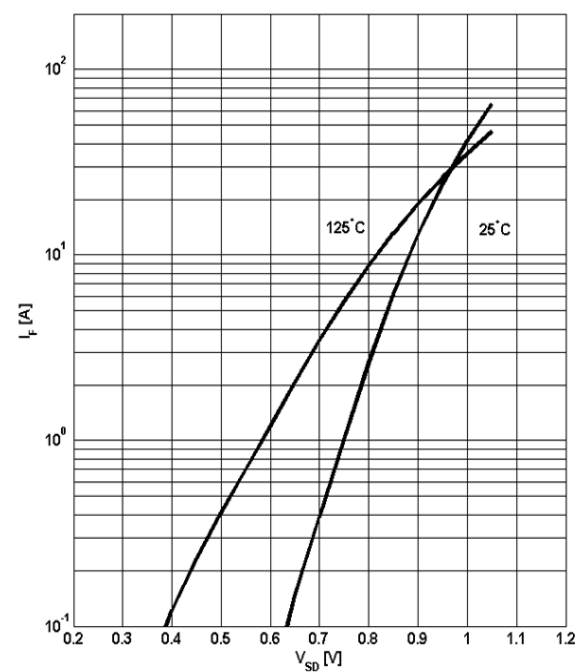

$I_F = f(V_{SD}); \text{parameter: } T_j$

Figure 15: Avalanche Energy

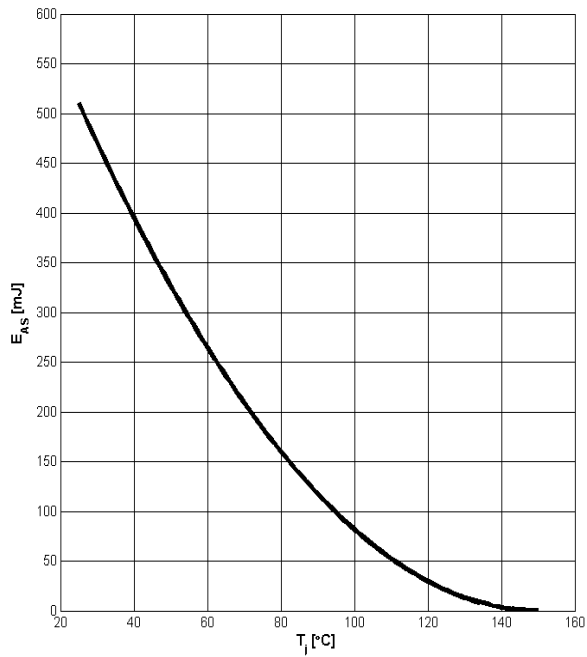

$E_{AS}=f(T_j); I_D=3.6A; V_{DD}=60V$

Figure 16: Typ. Capacitances

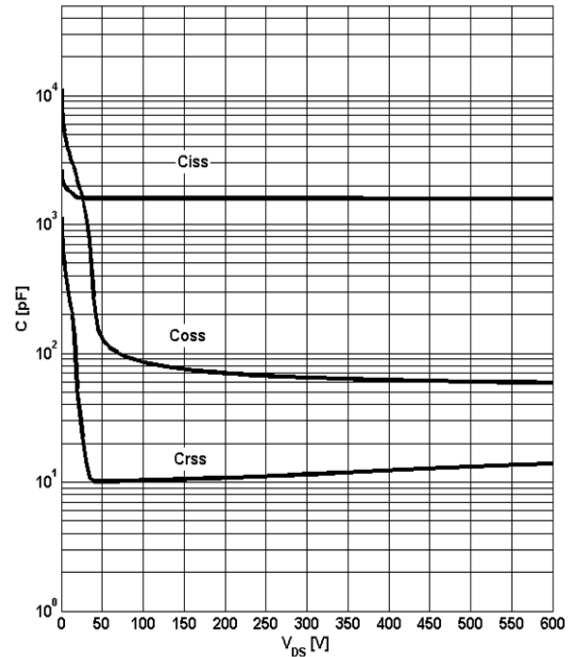

$C=f(V_{DS}); V_{GS}=0; f=1MHz$

Figure 17: Coss Stored Energy

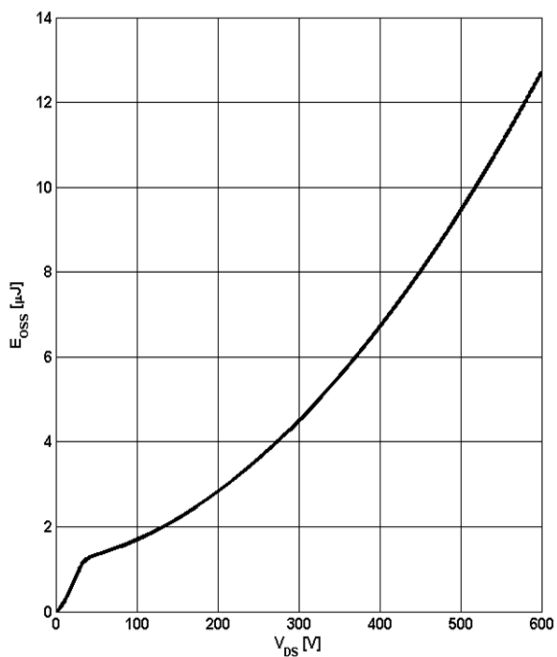

$E_{OSS}=f(V_{DS})$

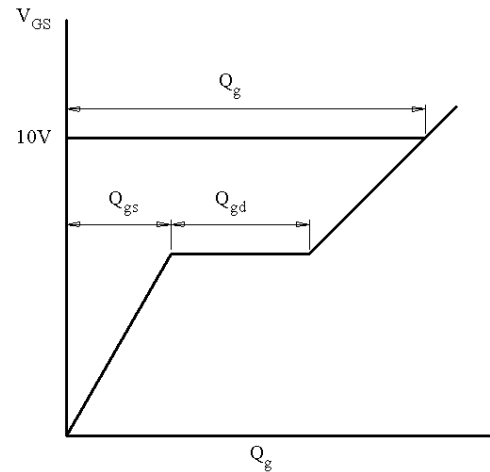
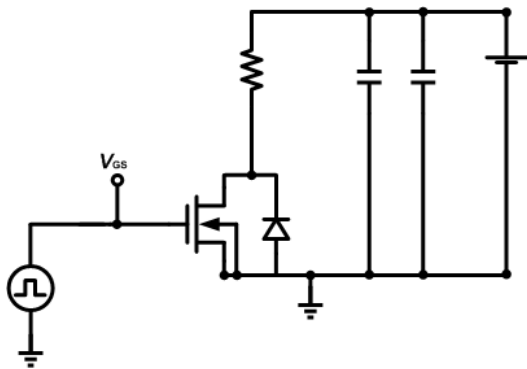
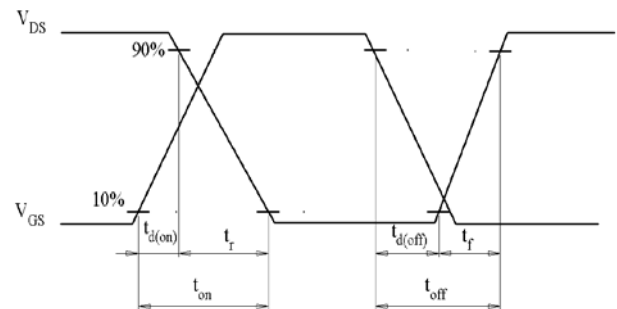
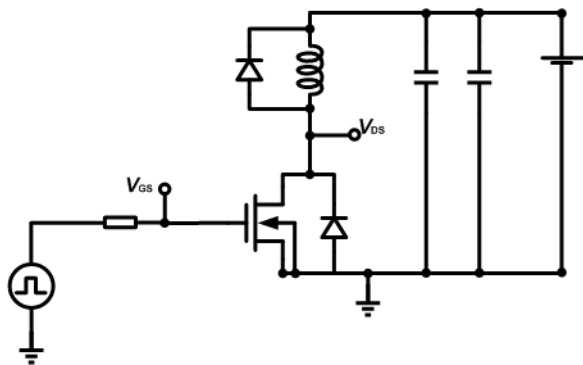
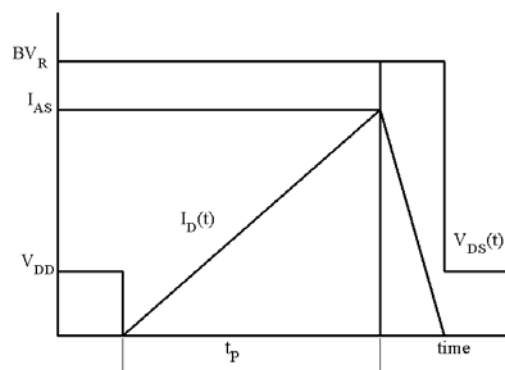
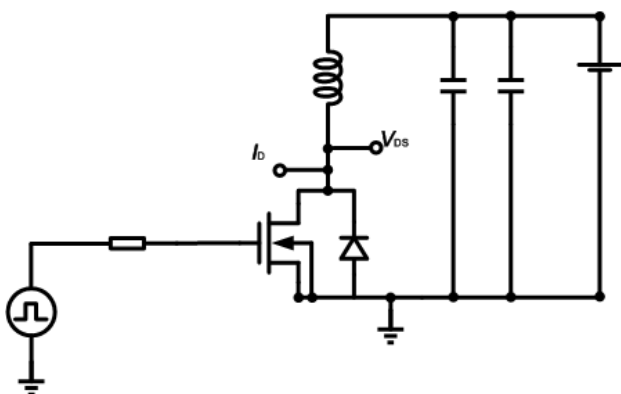
**Test Circuits**
**1. Gate Charge Test Circuit & Waveform**

**2. Switch Time Test Circuit**

**3. Unclaimed Inductive Switching Test Circuit & Waveforms**

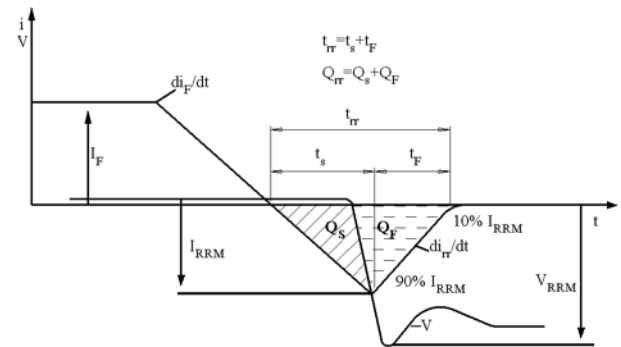
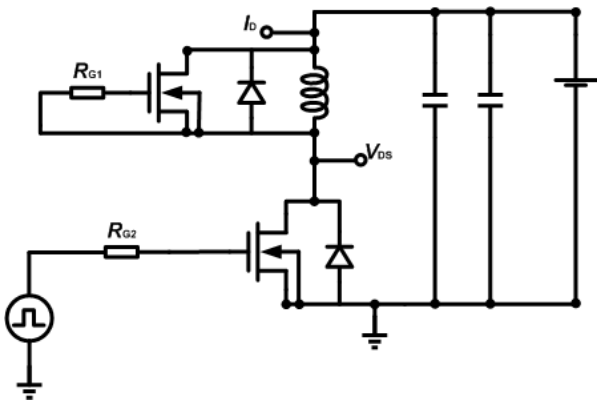

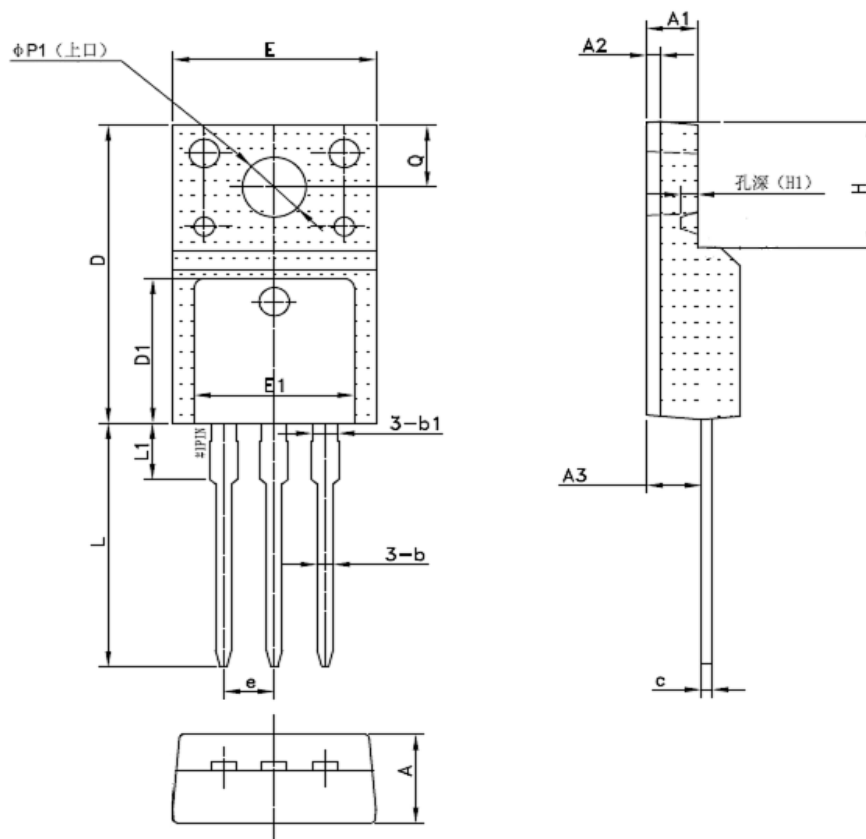
**4. Test Circuit and Waveform for Diode Characteristics**



**Mechanical Dimensions**
**TO-220F**
**Unit: mm**

Symbol	Dimensions(mm)		
	Min.	Typ.	Max.
A	4.30	4.70	4.90
A1	2.34	2.54	2.90
A2	-	0.70	-
A3	2.56	2.76	2.96
b	0.55	-	0.95
b1	-	1.28	-
c	0.42	0.50	0.70
D	14.70	-	16.07
D1	-	7.70	-
E	9.96	10.16	10.36
E1	-	8.00	-
e	2.54(BSC)		
H	-	6.70	-
(H1)	-	(0.81)	-
L	12.48	12.98	13.50
L1	-	2.93	-
ΦP1	-	3.18	-
Q	2.90	3.30	3.50

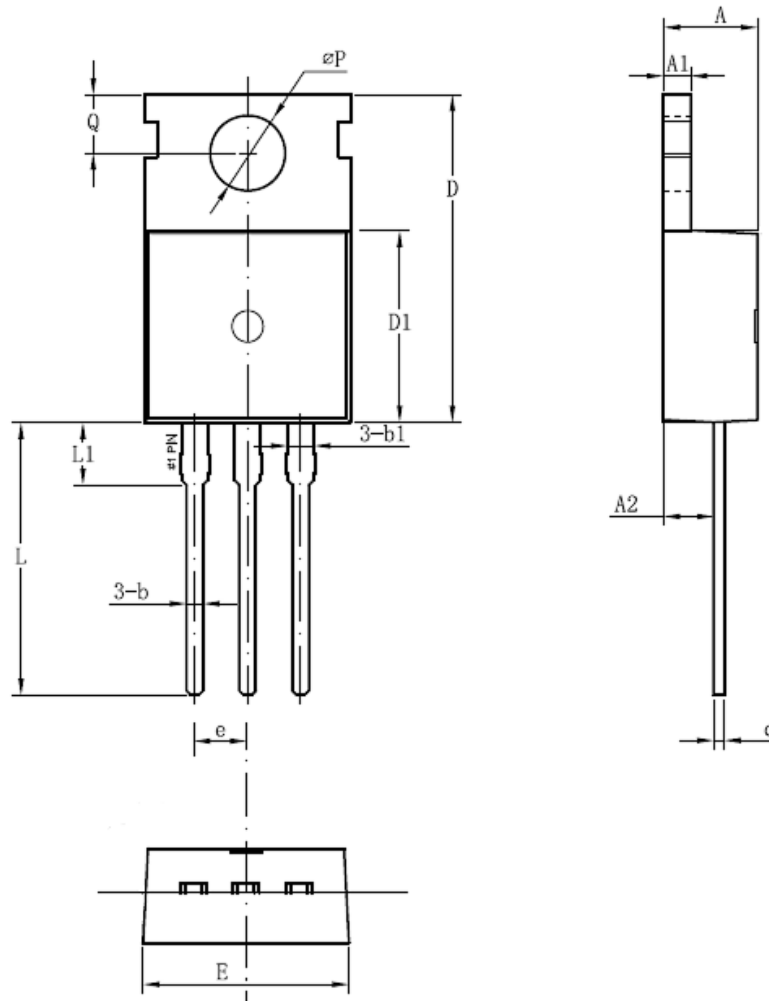
**Mechanical Dimensions (Continued)**
**TO-220C**
**Unit: mm**

Symbol	Dimensions(mm)		
	Min.	Typ.	Max.
A	4.30	4.50	4.70
A1	1.20	1.30	1.40
A2	2.20	2.40	2.60
b	0.70	0.80	0.95
b1	-	1.27	-
c	0.40	0.50	0.65
D	15.20	15.70	16.20
D1	9.00	9.20	9.40
E	9.70	10.00	10.20
e	2.54(BSC)		
L	12.60	13.08	13.60
L1	-	3.00	-
$\phi P$	3.50	3.60	3.80
Q	2.60	2.80	3.00



TM

**Sanrise Tech**  
**尚阳通**

Sanrise Technology Limited Company

<http://www.sanrise-tech.com>**IMPORTANT NOTICE**

Sanrise Technology Limited Company reserves the right to make changes without further notice to any products or specifications herein. Sanrise Technology Limited Company does not assume any responsibility for use of any its products for any particular purpose, nor does Sanrise Technology Limited Company assume any liability arising out of the application or use of any its products or circuits. Sanrise Technology Limited Company does not convey any license under its patent rights or other rights nor the rights of others.

**Main Site:****- Headquarter**

Sanrise Technology Limited Company  
Rm.601~603, Building B, SDG Information Port, No.2,  
Kefeng Road, Science & Technology Park, Nanshan District,  
ShenZhen, China  
Tel: +86-755-22953335  
Fax: +86-755-22916878

**- Shanghai Office**

Sanrise Technology Limited Company  
No. 1159, Cailun Road, Zhangjiang HiTech Park,  
Pudong District, Shanghai, China  
Tel: +86-21-51355061